

TAPlus Series

Digital Texture Analysis Machine

The TAPlus series machine is an easy to use system for performing rapid, detailed texture analysis tests on applications up to 1 kN (225 lbf). The machine uses interchangeable XLC Series loadcells as the measurement device. Tension and compression testing with cycling to load and extension limits are standard features. The machine can be equipped with a selection of specially engineered food texture grips, jigs and probes, as well as a range of multi-purpose grips for more general applications.

The TAPlus features an innovative design that maximises working space and simplifies operation and maintenance. The large work surface accommodates a broad range of specimen sizes and can be specified with additional work platforms for specialised applications.

The TAPlus displays load and extension information on a highly legible LCD console with integral membrane keypad. The machine's intuitive firmware displays prompts and menus which guide an authorised user through machine operations. Users can choose from a range of display languages.

The machine's performance can be further enhanced when combined with our NEXYGEN™ FM application software. This WINDOWS® based software is equally easy-to-use and allows detailed, fully customisable texture analysis tests to be performed, storing and displaying results in graphical and tabular formats. The software contains an extensive library of pre-programmed texture analysis test setups based around international standards. Results data can be extensively manipulated to produce detailed analytical reports, with the ability to integrate with popular WINDOWS® software packages including EXCEL®, ACCESS®, WORD®, POWERPOINT® and OUTLOOK®.

Features

- Large Working Area
 - Flexible Work Surface Configurations
 - 175 mm (6.9 in) Throat for Large Specimens
- Flexible and Accurate Load Measurements
 - XLC Series Loadcells
- Intuitive Operator Interface
 - Menu Driven with Intelligent Prompts
 - Membrane Keypad with Tactile Feedback
 - Highly Legible, backlit LCD Display
- Integral Cabling
- Motor Servo Control System
- Flash Memory Upgradeable
- Full PC Integration with NEXYGEN™ FM Software
- Load Rate Control
- Extensive range of texture analysis grips, jigs and probes available

Specifications

Capacity:	1 kN (225 lbf)
Crosshead Speed:	0.05 to 1270mm/min
(at full load)	0.002 to 50 in/min
Speed Accuracy:	<0.2%
Loadcell Accuracy:	±0.5% of reading
Extension Resolution:	Better than <1.3 microns (0.0013 mm)
Standard Travel:	500mm (20 in)
Data Acquisition Rate:	8 kHz
Display:	40 character x 4 line backlit LCD
Inputs:	RS232 Serial Data Digital and analogue Extensometer
Outputs:	RS232 Serial Data Analogue 10Vdc max (optional)
Standard Languages:	English, Danish, Italian, French, German
Power:	115/230V ac 50-60Hz
Measuring System:	Exceeds the requirements of BS EN ISO 7500:1999. Class 0.5 or Class1, ASTM E4, DIN 51221
Safety Features:	Emergency Stop, Frame Overload Protection, Loadcell Overload Protection, Operator Password.
Weight:	46 Kg (101 lb)
Warranty:	2 years



SPECIFICATION
SS-MT-6124-0901
September 2001

www.ametek.com
www.chatillon.com
www.lloyd-instruments.co.uk

AMETEK and CHATILLON are registered trademarks of AMETEK, inc.
LLOYD INSTRUMENTS, NEXYGEN and ONDIO are trademarks of AMETEK, inc.

Copyright 2001, by AMETEK, inc.

LLOYD
INSTRUMENTS™
A trademark of AMETEK Inc.

Ordering Information

Order No. Description

01/TAL **BASE Model Number - 1st to 6th Character**
LLOYD TAPlus Testing Machine

Travel Length - 7th Character
S Standard, 500 mm (20 in)

Measurement Adapter - 8th to 10th character
/LX XLC Load Cell Adapter Kit.

Work Surface - 11th Character
A Standard Base
B Expanded Work Table - M6 Threads
C Expanded Work Table - 10-32 UNF Threads
D T-Slot Table
E Drip Tray

Mains Power - 12th to 14th Character
/US 120V ac Mains Power
/UK 230V ac Mains Power
/EU 230V ac Mains Power

01/TAL S /LX E /US Sample Order Number - (01/TALS/LXE/US)
LLOYD TAPlus Testing Machine, with drip tray and 120V ac power.

(Standard system includes the base unit, drip tray, food testing base and 1/2" prob. All food testing attachments need to be ordered separately)

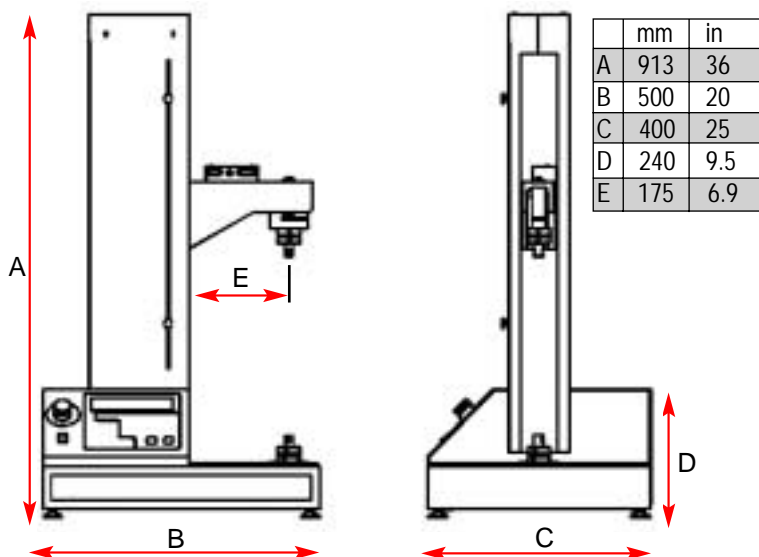

AMETEK
TEST AND CALIBRATION INSTRUMENTS

Accessories

Item Part No.

Loadcells:

5 N (1 lbf)	01/2946
10 N (2 lbf)	01/2360
20 N (4 lbf)	01/2950
50 N (11 lbf)	01/2361
100 N (22 lbf)	01/2480
250 N (55 lbf)	01/2992
500 N (110 lbf)	01/2362
1000 N (225 lbf)	01/2419

Application Software:

NEXYGEN™ FM	40/0738
NEXYGEN™ MT	40/0658
NEXYGEN™ MT (upgrade)	40/0658/NR

Grips & Fixtures:

All grips up to a capacity of 10 kN (2200 lbf) can be used. Specification sheet numbers for the range are indicated below:

Wire, Yarn & Thread Grips	SS-MT-6422
Food Texture Analysis Grips	SS-MT-6420
Wedge Grips	SS-MT-6409
Vice Grips	SS-MT-6408
Friction, Peel, Paper & Adhesive Grips	SS-MT-6407
Self Tightening Grips	SS-MT-6406
Pneumatic Grips	SS-MT-6405
Flexural Grips	SS-MT-6403
Compression Platens	SS-MT-6402
Chuck & Colett	SS-MT-6401

Work Tables:

Expanded Work Table (350 mm x 400 mm) with M6 tapped holes for custom fixings:	SPK/LFM/0007
Expanded Work Table (350 mm x 400 mm) with 10 - 32 tapped holes for custom fixings:	SPK/LFM/0008
Aluminium T-Slot Table (180 mm x 340 mm) for adjustable fixings:	SPK/LFM/0009
Drip Tray for food testing:	SPK/LFM/0010

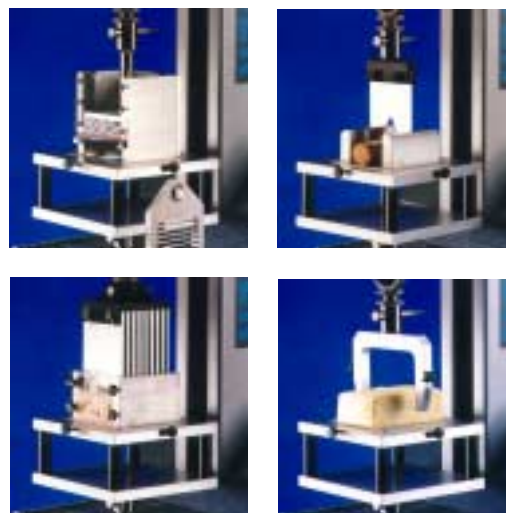

Examples of Texture Analysis grips & fixtures

WINDOWS, EXCEL, ACCESS AND POWERPOINT are registered trademarks of Microsoft Corporation

UK
Lloyd Instruments Ltd
Forum House
12 Barnes Wallis Road
Segensworth East, Fareham
Hampshire, PO15 5TT
UK
Tel: +44 (0)1489 486 399
Fax: +44 (0)1489 885 118

America
AMETEK TCI Division
8600 Somerset Drive
Largo
Florida 33773
USA
Tel: +1 (727) 536 7831
Fax: +1(727) 539 6882

Far East
Lloyd Instruments
Far East Representative Office
No7 Sherwood Place
Alexander Heights
6064 Perth
WESTERN AUSTRALIA
Tel: +61 8 9343 5725
Fax: +61 8 9343 5723

France
Lloyd Instruments SA
3 avenue des Coudriers
Zone d'activite de l'observatoire
78180 Montigny-Le-Bretonneux
FRANCE
Tel: +33 (1) 30 57 47 74
Fax: +33 (1) 30 57 50 33

Germany
AMETEK Precision Instruments
Europe GmbH
Rudolf-Diesel-Straße 16
D-40670 Meerbusch
GERMANY
Tel: +49 (0)2159 9136-70
Fax: +49 (0)2159 9136-80

email: general@lloyd-instruments.co.uk
www.lloyd-instruments.co.uk

Information within this document is subject to change without notice.

ISO 9001
Manufacturer